

# Pallas/150

Compact stand-aid

## Primary application

Home care  
Nursing homes  
Hospital

Ergolet Pallas 150 is probably the most compact stand aid on the market today making it the ideal choice for home care use, while still being suited for nursing home or hospital use.

Despite its small size the Pallas can lift both short and tall people who, to some extent, can actively assist during the transfer. The lifting pattern is close to the natural way of standing up ensuring that the user is transferred safely and comfortably.

The multi adjustable knee support ensures optimum comfort and support when lifting users of different heights.

Remove the foot tray and a seated sling transfer can be made with the knee support providing added comfort and security. Remove both knee support and foot tray and the unit can be used for gait training.

The stand aid can be used as a mobile lifter.

## Key standard functions

Compact size  
High weight lifting  
On board charging  
Large capacity batteries  
Electrical emergency lowering function

## Accessories

Complete selection of lifting slings  
Choice of foot platforms  
Handgrips  
T-grip



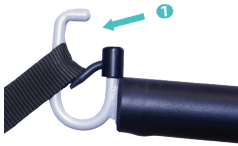

Sling attachment.

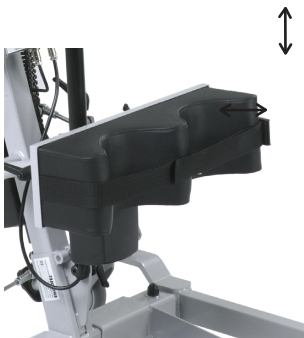

Multi adjustable knee support for increased comfort.



T-grip



Add on handles.

## PRODUCT HIGHLIGHTS

- Class leading compact size
- Knee support adjustable in height, angle and depth
- Foot plate blocks for increased height
- Ergonomic handles with several gripping positions
- Low friction wheels
- Electrical emergency lowering.

Version	Item-number
Pallas 150 manual leg spreading	011-01526
Pallas 150 electrical leg spreading	011-01528
Accessories	
Foam platform 5 cm	750-33010
Foam platform 10 cm	750-33015
Add on handles for lifting arm	017-00010
T-grip	017-00001
Foot holders	017-01420

## TECHNICAL SPECIFICATION

Max. load	150 kg
Lifting interval min/max	597 / 1665 mm
Width external , base min/max	605 / 882 mm
Width internal, base min/max	495 / 722 mm
Knee support adjustment	310 / 410 mm
Chassis height front/back	125 / 165 mm
Length of legs	865 mm
Lifting method	Electrical
Leg spreading method	Manual / Electrical
Emergency lowering	Electrical
Emergency stop	Electrical
Turning radius	1025 mm
Wheel diameter front/back	ø75 / ø100
Total weight	45kg
Weight heaviest single part	15kg

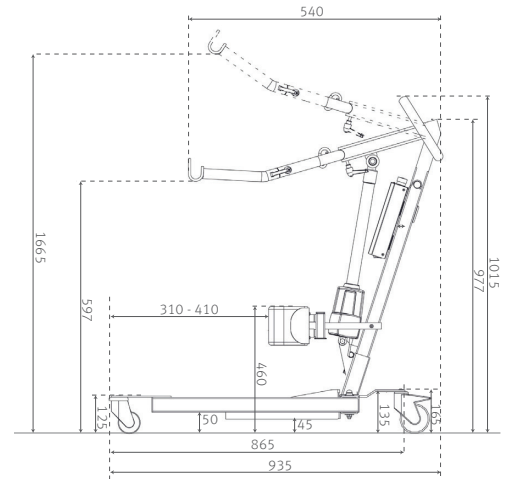
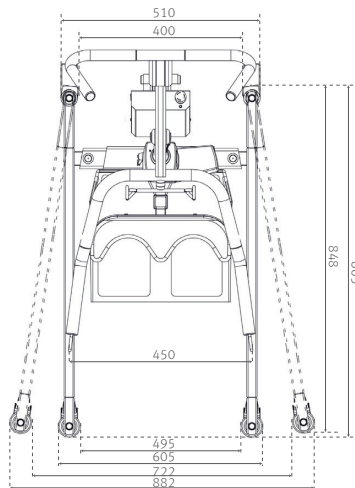

Consult the Technical manual for further specifications. All figures and measurements are for guidance only and may differ in actual situations. Ergolet reserves the right to changes without notice.

Product photos may include accessories. Consult your dealer.



date 16.04.2021 - ver. 7

WinnCare Nordic ApS  
 Taarnborgvej 12C  
 4220 Korsøer  
 Denmark  
 tel. +45 70 27 37 20  
 e-mail: info@winncare.dk

[www.winncare.dk](http://www.winncare.dk)

**WINN**CARE  
 N o r d i c